

# Diesel Systems Departronic 2

## Heavy-Duty Commercial & Off-Highway Applications



All over the world, diesel engines have to comply with a large number of emission targets which include ever stricter particulate emission limits. This is why more and more diesel engines are being equipped with a closed (wall flow) diesel particulate filter.

These particulate filters need to be regenerated in order to remove the trapped soot. One way is to actively regenerate the filter at regular intervals in order to reliably burn off the stored particulates. To do this, temperatures of around 600°C in the particulate filter are required. Exhaust temperatures this high could be achieved via internal engine measures alone. This can, however, lead to a dilution of the engine lubrication oil and reduced oil-change intervals.

Alternatively, the targeted injection of diesel fuel into the exhaust gas via the Departronic helps to significantly reduce or even avoid the need for internal engine measures. This procedure increases the efficiency of active regeneration and thus saves fuel.

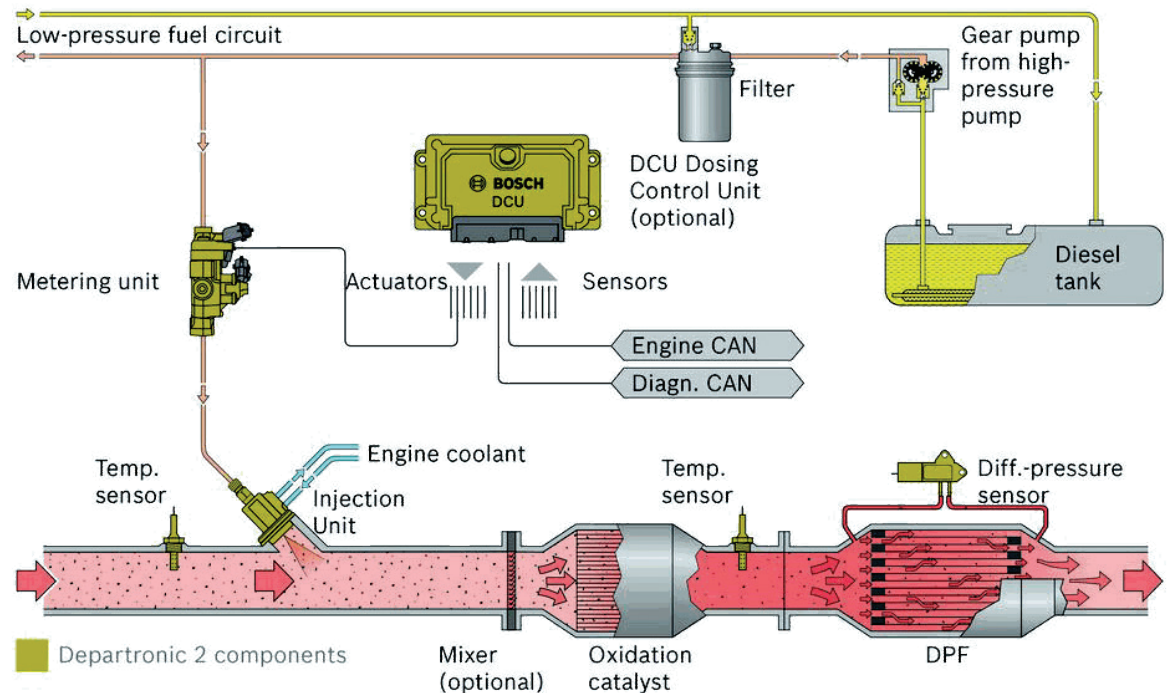
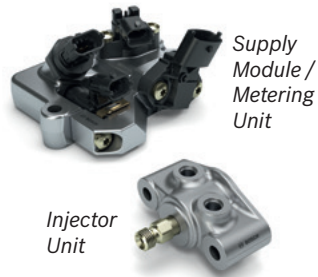

### Key Applications

OE Bosch PN	IAM Bosch PN	Description	Application	Spare Part	Start Model Year	End Model Year
0444031018	0444031017	Supply Module	Detroit Diesel		2015	Current
0444031001	0444031001	Supply Module	John Deere		2011	Current
0444031002	0444031002	Supply Module	John Deere		2010	Current
0444031003	0444031003	Supply Module	John Deere		2011	2014
0444031004	0444031004	Supply Module	Navistar		2010	2016
0281006099	0281006099	Injection Valve	Detroit Diesel			
0444032001	0444032006	Injection Unit	Detroit Diesel	0281006099	2007	2010
0444032002	0444032007	Injection Unit	Detroit Diesel	0281006099	2007	2010
0444033010	0444033002	Injection Unit	Navistar	0281006099	2014	2016
0444033009	0444033008	Injection Unit	John Deere	0281006099	2013	Current

IAM Bosch PN	OE Bosch PN	OE Xref	Brand
0444031017	0444031018	936 070 04 55	Detroit Diesel
0444031001	0444031001	RE 54 299 2	John Deere
0444031001	0444031001	RE 54 143 8	John Deere
0444031002	0444031002	RE 54 299 6	John Deere
0444031002	0444031002	RE 53 886 0	John Deere
0444031003	0444031003	RE 54 290 5	John Deere
0444031003	0444031003	RE 53 924 0	John Deere
0444031004	0444031004	3015291C1	Navistar
0444031004	0444031004	3006082C1	Navistar
0281006099	0281006099	472 070 07 46	Detroit Diesel
0444032006	0444032001	000 070 55 46	Detroit Diesel
0444032006	0444032001	460 070 02 46	Detroit Diesel
0444032007	0444032002	472 070 02 46	Detroit Diesel
0444032007	0444032002	472 070 04 46	Detroit Diesel
0444033002	0444033010	3006107C91	Navistar
0444033002	0444033010	3006201C1	Navistar
0444033008	0444033009	RE 55 683 1	John Deere

